



Rizzetta & Company

Somerset Community Development District

**Board of Supervisors' Meeting
February 5, 2026**

District Office:
120 Richard Jackson Blvd, Suite 220
Panama City Beach, Florida 32407
850-629-0153

www.somersetcdd.org

SOMERSET COMMUNITY DEVELOPMENT DISTRICT AGENDA

Alys Beach Conference Room, located at 85 Elbow Beach Road, Building 1,
Alys Beach, Florida 32461

Board of Supervisors	Robert Stenhammer John Rosenberg George Hartley Belinda Ballew Tom Dodson	Chairman Vice Chairman Assistant Secretary Assistant Secretary Assistant Secretary
District Manager	Kimberly O'Mera	Rizzetta & Company, Inc.
District Counsel	Tucker Mackie	Kutak Rock, LLP
District Engineer	Jim Martelli	Innerlight Engineering

All Cellular phones and pagers must be turned off while in the meeting room.

The Public Comment portion of the agenda is where individuals may make comments on any matters that concern the District. Individuals are limited to a total of three (3) minutes to make comments during this time.

Pursuant to provisions of the Americans with Disabilities Act, any person requiring special accommodations to participate in this meeting/hearing/workshop is asked to advise the District Office at least forty-eight (48) hours before the meeting, hearing, and/or workshop by contacting the District Manager at (850) 334-9055. If you are hearing or speech impaired, please contact the Florida Relay Service by dialing 7-1-1, or 1-800-955-8771 (TTY) 1-800-955-8770 (Voice), who can aid you in contacting the District Office.

A person who decides to appeal any decision made at the meeting/hearing/workshop with respect to any matter considered at the meeting/hearing/workshop is advised that person will need a record of the proceedings and that accordingly, the person may need to ensure that a verbatim record of the proceedings is made including the testimony and evidence upon which the appeal is to be based.

SOMERSET COMMUNITY DEVELOPMENT DISTRICT

District Office • 120 Richard Jackson Blvd, Suite 220, Panama City Beach, FL 32407

Mailing Address • 3434 Colwell Avenue, Suite 200, Tampa, FL 33614

www.SomersetCDD.org

January 29, 2026

Board of Supervisors
Somerset Community
Development District

FINAL AGENDA

Dear Board Members:

The Regular Meeting of the Board of Supervisors of the Somerset Community Development District will be held on **Thursday, February 5, 2026, at 2:00 p.m. (Central Time)** at the Somerset Conference Hall, located at 215 Nonesuch Way, Alys Beach, FL 32461. The following is the Final Agenda for this meeting:

1. **CALL TO ORDER/ROLL CALL**
2. **AUDIENCE COMMENTS ON AGENDA ITEMS**
3. **BUSINESS ADMINISTRATION**
 - A. Consideration of Minutes of the Board of Supervisors Meeting Held on December 4, 2025 Tab 1
 - B. Ratification of Operation and Maintenance Expenditures for month of November 2025 Tab 2
4. **CONSENT AGENDA – RATIFICATION OF MAINTENANCE ITEMS** Tab 3
 - A. Alys Beach Resorts: PO #26-01: RR-01 Streetlight Materials
 - B. McHenry Electric:
 1. WA #26-07: RR-01 Streetlight Replacement
 2. WA #26-09: Whalebone Alley Streetlights
 3. WA #26-10: Troubleshoot Ped Path Lighting DD
 - C. Rip’s Professional Lawn Care
 1. WA #26-03: West End Irrigation Repair 30A
 2. WA #26-04: East Well Meter Replacement
 3. WA #26-06: Irrigation Repair – Near East Well
 4. WA #26-07: Irrigation Repair – Hoover
 5. WA #26-08: Irrigation Repair – P18
 6. WA #26-09: Irrigation Monitoring System
 7. WA #26-10: Irrigation Repair – 30A/Neat
 8. WA #26-11: Repair Main Line Silva at Whitten Way
 9. WA #26-12: Irrigation Repair – Silva Common
 10. WA #26-13: Damage to turf along 30A
 11. WA #26-14: Irrigation Repair – EE20-21
 - D. Juniper Landscaping of Florida
 1. WA #26-02: Irrigation Repair – East Buttery
 2. WA #26-03: Irrigation Repair – U45
 3. WA #26-04: Lake Marilyn Float Repair
5. **BUSINESS ITEMS**
 - A. Continued Discussion and Consideration of Dune Modification Policy.....Tab 4
 - B. Consideration of Proposal for Paver Repairs – Couch Collective.....Tab 5
6. **STAFF REPORTS**
 - A. District Counsel
 - B. District Engineer
 - C. Facilities Manager
 - D. District Manager
 1. Presentation of District Manager ReportTab 6

7. SUPERVISOR REQUESTS AND COMMENTS
8. ADJOURNMENT

I look forward to seeing you at the meeting. In the meantime, if you have any questions, please do not hesitate to call me at 850-629-0153.

Sincerely,
Kimberly O'Mera
Kimberly O'Mera
District Manager

Tab 1

MINUTES OF MEETING

Each person who decides to appeal any decision made by the Board with respect to any matter considered at the meeting is advised that the person may need to ensure that a verbatim record of the proceedings is made, including the testimony and evidence upon which such appeal is to be based.

SOMERSET
COMMUNITY DEVELOPMENT DISTRICT

The regular meeting of the Board of Supervisors of the Somerset Community Development District was held on **Thursday, December 4, at 2:00 p.m. (Central Time)** at the Somerset Conference Hall, located at 215 Nonesuch Way, Alys Beach, FL 32461.

Present and constituting a quorum:

Robert Stenhammer	Board Supervisor, Chairman
John Rosenberg	Board Supervisor, Vice Chairman
George Hartley	Board Supervisor, Assistant Secretary
Tom Dodson	Board Supervisor, Assistant Secretary

Also present were:

Kimberly O'Mera	District Manager, Rizzetta & Company, Inc.
Jim Martelli	District Engineer, Innerlight Engineering
Tucker Mackie	District Counsel, Kutak Rock, LLP.
Doug Lang	Facilities Management, Alys Beach Resorts, LLC.
Mike Spann	Facilities Management, Alys Beach Resorts, LLC.

FIRST ORDER OF BUSINESS

Call to Order

Ms. O'Mera called the meeting to order at 2:03 p.m. and read the roll call, confirming a quorum for the meeting.

SECOND ORDER OF BUSINESS

Audience Comments on Agenda Items

There were no audience members present to comment.

42 **THIRD ORDER OR BUSINESS**

**Consideration of Minutes of the Board
of Supervisors Meeting Held on
October 2, 2025**

43
44
45

On a motion by Mr. Dodson, seconded by Mr. Rosenberg, with all in favor, the Board approved the Minutes of the Regular Meeting of the Board of Supervisors held on October 2, 2025, for Somerset Community Development District.

46
47

48 **FOURTH ORDER OR BUSINESS**

**Ratification of Operation and
Maintenance Expenditures for the
Months of September - October 2025**

49
50
51

Ms. O'Mera presented the maintenance expenditures to the Board of Supervisors and asked if there were any questions. There were no questions.

54

On a motion by Mr. Stenhammer, seconded by Mr. Rosenberg, with all in favor, the Board ratified the Operations and Maintenance Expenditures for the month of September 2025 in the amount of \$95,488.88, and October 2025 in the amount of \$142,849.64, for Somerset Community Development District.

55
56
57
58
59
60
61
62
63
64
65
66
67
68
69
70
71
72
73
74
75

76 **FIFTH ORDER OR BUSINESS**

**Consideration Consent Agenda –
Ratification of Maintenance Items**

77
78

79 Ms. O’Mera presented maintenance items for discussion and ratification by the Board.

On a motion by Mr. Stenhammer, seconded by Mr. Rosenberg, with all in favor, the Board ratified the following expenditures:

by Couch Collective:

- WA #26-01: Revised – Beach Club Plaza Lighting Replacements: \$22,330.00

by McHenry Electric:

- WA #25-30: South Firepit Lighting S Sea Garden: \$2,350.00
- WA #26-01: K Parking Court Lighting: \$2,287.50
- WA #26-03: Clermont Court Park Lights Repair: \$1,200.00
- WA #26-04: Employee Parking Lot Lighting Repairs: \$4,674.75
- WA #26-05: Gulf Green Ped Path Lighting Repair: \$325.00
- WA #26-06: East Well Power Repair: \$1,278.20

by Mills Supply:

- WA #25-03: Pump Station Service Calls: \$1,320.00
- WA #26-01: Hoover Repair: \$610.00

by Rip’s Professional Lawn Care:

- WA #26-01: Irrigation Repair (D-4): not-to exceed \$4,000.00
- WA #26-02: Replacement of Valve Boxes on 30A: \$3,179.00

for Somerset Community Development District.

80
81
82
83
84
85

SIXTH ORDER OR BUSINESS

**Consideration of Proposals for Rock
Replacement Along 30A Corridor**

86 Ms. O’Mera presented the proposals for rock replacement along the 30A corridor.

On a motion by Mr. Rosenberg, seconded by Mr. Dodson, with all in favor, the Board approved the 30A Palm Tree Rock Replacement proposal from Juniper Landscaping of Florida, LLC., in the amount of \$57,648.00, as a disbursement from Reserves, for Somerset Community Development District.

87
88
89
90

91 **SEVENTH ORDER OR BUSINESS** **Consideration of Landscape**
92 **Maintenance Agreement Proposals**
93

94 Ms. O'Mera turned presentation over to Mr. Stenhammer who presented the proposals received
95 in response to the information request for landscape maintenance proposals.
96

On a motion by Mr. Dodson, seconded by Mr. Hartley, with all in favor, the Board approved the proposal from Juniper Landscaping of Florida, LLC. for landscape maintenance services, in the annual amount of \$111,640, for Somerset Community Development District.

97
98 **EIGHTH ORDER OF BUSINESS** **District Goals and Objectives**

99 Ms. O'Mera presented the District Goals and Objectives for review. The Board discussed the goals
100 and objectives for Fiscal Year 2024/2025 and the adoption of Fiscal Year 2025/2026.

On a motion by Mr. Stenhammer, seconded by Mr. Rosenberg, with all in favor, the Board approved the District Goals and Objectives for Fiscal Year 2025/2026, for Somerset Community Development District.

101
102
103
104
105
106
107
108
109
110
111
112
113
114
115
116
117
118
119
120
121
122
123

NINTH ORDER OF BUSINESS

Staff Reports

A. District Counsel

Ms. Mackie noted that District Counsel is working with the Homeowners Association on the development of a proposed Dune Modification Policy, which is expected to be presented to the Board in early 2026, requiring a formal rule-making process. Ms. Mackie invited questions from the Board. There were no questions.

B. District Engineer

Mr. Martelli presented an update regarding stormwater inspections, noting that the firm is in the process of procuring a new camera and anticipates completion in the first quarter of 2026. Mr. Martelli invited questions from the Board. There were no questions.

C. Facilities Manager

Mr. Lang discussed standardizing street and stop sign signage throughout the district. Mr. Spann noted that a spare crosswalk assembly would be kept on hand. There were no questions.

D. District Manager

Ms. O'Mera presented the District Manager's Report and noted that dune maintenance report would be discussed at the next meeting. Ms. O'Mera invited questions from the Board. There were no questions.

TENTH ORDER OF BUSINESS

Supervisor Requests and Audience Comments

There being no audience present, there were no comments.

ELEVENTH ORDER OF BUSINESS

Adjournment

167
168

On a motion by Mr. Hartley, seconded by Mr. Rosenberg, with all in favor, the Board adjourned the meeting at 2:45 p.m., for Somerset Community Development District.

169
170
171
172
173

Secretary/Assistant Secretary

Chairman/ Vice Chairman

DRAFT

Tab 2

SOMERSET COMMUNITY DEVELOPMENT DISTRICT

District Office · Panama City, Florida · (850) 334-9055
Mailing Address · 3434 Colwell Avenue, Suite 200, Tampa Florida 33614
www.somersetcdd.org

Operations and Maintenance Expenditures November 2025 For Board Approval

Attached please find the check register listing the Operation and Maintenance expenditures paid from November 1, 2025 through November 30, 2025. This does not include expenditures previously approved by the Board.

The total items being presented: **\$74,838.18**

Approval of Expenditures:

_____ Chairperson

_____ Vice Chairperson

_____ Assistant Secretary

Somerset Community Development District

Paid Operation & Maintenance Expenditures

November 1, 2025 Through November 30, 2025

<u>Vendor Name</u>	<u>Check Number</u>	<u>Invoice Number</u>	<u>Invoice Description</u>	<u>Invoice Amount</u>
ALYS Beach Neighborhood Association	300194	10202025	Unclog Storm Drains 10/25	\$ 4,360.00
ALYS Beach Resort LLC	300205	CL00027585	Monthly Facility Management 10/25	\$ 8,381.00
Aqua Pro Water Systems - FL/GA	300195	116045716	Chemical/Salt Installation 10/25	\$ 285.00
Aqua Pro Water Systems - FL/GA	300195	116045738	Chemical/Salt Installation 10/25	\$ 255.00
Aqua Pro Water Systems - FL/GA	300195	116045760	Chemical/Salt Installation 10/25	\$ 150.00
Aqua Pro Water Systems - FL/GA	300195	116045782	Chemical/Salt Installation 10/25	\$ 180.00
Aqua Pro Water Systems - FL/GA	300195	116238008	Chemical/Salt Installation 10/25	\$ 375.00
Aqua Pro Water Systems - FL/GA	300195	116238030	Chemical/Salt Installation 10/25	\$ 435.00
Aqua Pro Water Systems - FL/GA	300195	116238052	Chemical/Salt Installation 10/25	\$ 375.00
Aqua Pro Water Systems - FL/GA	300195	116492145	Chemical/Salt Installation 10/25	\$ 225.00
Aqua Pro Water Systems - FL/GA	300195	116492167	Chemical/Salt Installation 10/25	\$ 270.00
Aqua Pro Water Systems - FL/GA	300195	116492189	Chemical/Salt Installation 10/25	\$ 270.00
Aqua Pro Water Systems - FL/GA	300195	116492211	Chemical/Salt Installation 10/25	\$ 180.00
Aqua Pro Water Systems - FL/GA	300195	116492234	Chemical/Salt Installation 10/25	\$ 360.00

Somerset Community Development District

Paid Operation & Maintenance Expenditures

November 1, 2025 Through November 30, 2025

<u>Vendor Name</u>	<u>Check Number</u>	<u>Invoice Number</u>	<u>Invoice Description</u>	<u>Invoice Amount</u>
Aqua Pro Water Systems - FL/GA	300195	116492256	Chemical/Salt Installation 10/25	\$ 285.00
Aqua Pro Water Systems - FL/GA	300195	116492278	Chemical/Salt Installation 10/25	\$ 240.00
Aqua Pro Water Systems - FL/GA	300195	116492300	Chemical/Salt Installation 10/25	\$ 120.00
Aqua Pro Water Systems - FL/GA	300195	124445898	Chemical/Salt Installation 10/25	\$ 195.00
Aqua Pro Water Systems - FL/GA	300195	124445920	Chemical/Salt Installation 10/25	\$ 255.00
Aqua Pro Water Systems - FL/GA	300195	124445942	Chemical/Salt Installation 10/25	\$ 375.00
Aqua Pro Water Systems - FL/GA	300195	124445964	Chemical/Salt Installation 10/25	\$ 255.00
Aqua Pro Water Systems - FL/GA	300206	116237986	Chemical/Salt Installation 10/25	\$ 495.00
Belinda Ann Ballew	300196	BB100225	Board of Supervisors Meeting 10/02/25	\$ 200.00
Dune Doctors, LLC	300197	080125-25	Quarterly Maintenance Phase Aug/25 - Oct/25	\$ 29,354.84
Florida Department of Commerce	20251126-01	92926 ACH	Special District Fee for FY 25/26	\$ 175.00
Florida Power & Light Company	20251117-01	2104633165-110325	9954 E COUNTY HIGHWAY 30A 10/25	\$ 468.14
Florida Power & Light Company	20251118-01	2108012465-110325	396 E COUNTY HIGHWAY 30A 10/25	\$ 235.67
Florida Power & Light Company	20251119-01	110325-2112535147 ACH	305 Somerset Street 10/25	\$ 3,056.57

Somerset Community Development District

Paid Operation & Maintenance Expenditures

November 1, 2025 Through November 30, 2025

<u>Vendor Name</u>	<u>Check Number</u>	<u>Invoice Number</u>	<u>Invoice Description</u>	<u>Invoice Amount</u>
Florida Power & Light Company	20251119-01	110325-2112535170 ACH	121 N CHARLES ST 10/25	\$ 181.76
Florida Power & Light Company	20251119-01	110325-2112535329 ACH	97 Nonesuch Way 10/25	\$ 31.57
Florida Power & Light Company	20251119-01	110325-2112535378 ACH	31 Hog Penny Aly 10/25	\$ 33.48
Florida Power & Light Company	20251119-01	110325-2112535477 ACH	101 N Somerset St 10/25	\$ 33.08
Florida Power & Light Company	20251119-01	110325-2112535527 ACH	69 N Charles St. Inlet 10/25	\$ 89.32
Florida Power & Light Company	20251119-01	110325-2112535568 ACH	147 W LA Garza Ln 10/25	\$ 30.10
Florida Power & Light Company	20251119-02	2112535816-110325	106 N Somerset Street 10/25	\$ 28.53
George Hartley	300198	GH100225	Board of Supervisors Meeting 10/02/25	\$ 200.00
Kutak Rock, LLP	300199	3613447	Legal Services 07/25	\$ 603.50
Kutak Rock, LLP	300199	3639696	Legal Services 08/25	\$ 3,047.00
Kutak Rock, LLP	300199	3643167	Legal Services 09/25	\$ 1,858.50
McHenry Electric, Inc.	300202	26637	Restored power to the East well 10/25	\$ 1,278.20
McHenry Electric, Inc.	300207	26672	Employee Parking / WA 26-04 11/25	\$ 4,674.75
Mills Supply	300203	10730	Hoover Repair - Broken Fitting 10/25	\$ 610.00
Rizzetta & Company, Inc.	300193	INV0000104559	District Management Services 11/25	\$ 9,447.17

Somerset Community Development District

Paid Operation & Maintenance Expenditures

November 1, 2025 Through November 30, 2025

<u>Vendor Name</u>	<u>Check Number</u>	<u>Invoice Number</u>	<u>Invoice Description</u>	<u>Invoice Amount</u>
Robert E Stenhammer	300200	RS100225	Board of Supervisors Meeting 10/02/25	\$ 200.00
The Lake Doctors, Inc.	300204	321393B	Monthly Monitoring/Inspection 11/25	\$ 55.00
Thomas M Dodson	300201	TD100225	Board of Supervisors Meeting 10/02/25	\$ 200.00
VGlobalTech	300208	7860	Website ADA Compliance 11/25	<u>\$ 425.00</u>
Report Total				<u>\$ 74,838.18</u>

Tab 3



CONSENT AGENDA – RATIFICATION OF MAINTENANCE ITEMS

A. Alys Beach Resorts	
1. PO #26-01: RR-01 Streetlights Materials.....	\$ 5,445.00
B. McHenry Electric	
1. WA #26-07: RR-01 Streetlights Replacement.....	\$ 2,350.00
2. WA #26-09: Whalebone Alley Streetlights.....	\$ 225.00
3. WA #26-10: Troubleshoot Ped Path Lighting DD.....	\$ 1,200.00
C. Rip's Professional Lawn Care	
1. WA #26-03: West End Irrigation Repair 30A.....	\$ 277.05
2. WA #26-04: East Well Meter Replacement.....	\$ 3,509.00
3. WA #26-06: Irrigation Repair - Near East Well.....	\$ 632.58
4. WA #26-07: Irrigation Repair - Hoover.....	\$ 3,884.50
5. WA #26-08: Irrigation Repair - P18.....	\$ 264.75
6. WA #26-09: Irrigation Monitoring System.....	\$ 4,439.60
7. WA #26-10: Irrigation Repair - 30A/Neat.....	\$ 778.67
8. WA #26-11: Repair Main Line Silva at Whitten Way.....	\$ 447.65
9. WA #26-12: Irrigation Repair - Silva Common.....	\$ 366.34
10. WA #26-13: Damage to turf along 30A.....	\$ 2,617.19
11. WA #26-14: Irrigation Repair - EE20-21.....	\$ 511.83
D. Juniper Landscaping of Florida	
1. WA #26-02: Irrigation Repair - East Buttery.....	\$ 395.55
2. WA #26-03: Irrigation Repair - U45.....	\$ 1,082.16
3. WA #26-04: Lake Marilyn Float Repair.....	\$ 562.19
	Total: \$28,989.06

Alys Beach Resorts

**PURCHASE ORDER AGREEMENT FOR GOODS
PO# 26-01**

DISTRICT		SELLER	
District:	Somerset Community Development District	Seller:	Alys Beach Resorts, LLC
Shipping Address:	Somerset Community Development District Attn: Alys Beach Town Operations 9581 E. County Highway 30A, Building D Alys Beach, Florida 32461	Mailing Address:	9581 E. County Highway 30A, Building D Alys Beach, Florida 32461 Attn: Doug Lang
Billing Address:	c/o Rizzetta & Company, Inc. 3434 Colwell Avenue, Suite 200 Tampa, Florida 33614	Local Office:	Same as above
Phone:	(850) 334-9055	Phone:	
Fax:		Fax:	

PROJECT			
Project Name:	T4 Streetlight Pole & Light Fixture	Proposal Date:	October 31,2025
Project Address:	RR-2 (RR-1)	Quotation #:	N/A

DESCRIPTION OF GOODS: T4 Streetlight Pole & Fixture. See **Exhibit A**.

SPECIFICATIONS ATTACHED	YES	NO	N/A	IF YES, DATED _____
SITE RULES ATTACHED	YES	NO	N/A	IF YES, TITLED AS _____
*DELIVERY DUE BY: _____				

TERM:

Single Purchase of Goods

***Delivery Date:** The Delivery Date shall be: As needed by McHenry Electric

PRICE:

Fixed Price

Price: \$5,445.00

IN WITNESS HEREOF, the parties have executed this Purchase Order Agreement for Goods (“Order”) effective as of the date executed below. By executing this document below, Seller acknowledges that it has read all of the terms and provisions of this Order and agrees to perform the services or deliver the goods as described herein and will comply fully with the terms and conditions hereof.

SOMERSET COMMUNITY DEVELOPMENT DISTRICT

District

Sign:

By: Robert Stenhammer
Robert Stenhammer (Dec 1, 2025 11:18:36 CST)

Name: **Robert Stenhammer**

Title: **Chairman**

Date Executed: **Dec 1, 2025**

ALYS BEACH RESORTS, LLC

Seller

Sign:

By: Douglas Lang
Douglas Lang (Dec 2, 2025 08:36:47 CST)

Name: **Douglas Lang**

Title: **Community projects and service manager**

Date Executed: **Dec 2, 2025**

TERMS AND CONDITIONS

DEFINITIONS

As used throughout this Order, the following definitions apply unless otherwise specifically stated:

- a. "Goods" means those part numbers, model numbers and/or descriptions set forth in Exhibit A.
- b. "Indemnified Parties" means (i) District, its Board of Supervisors, agents, officers, and employees, the Engineer, District Manager, and such other parties as District may reasonably request. Any one of the foregoing is an "Indemnified Party."
- c. "Project" means the delivery of the Goods.

GENERAL PROVISIONS

1. PRICE. The Price set forth above includes all applicable taxes, recognizing the tax-exempt status of the District, and all tools, equipment, supplies, insurance and other materials or services (including without limitation all packing, loading or freight) necessary to deliver the Goods, with the exception that the freight number may change based on actual freight costs.

2. TERMS OF PAYMENT. Seller's Invoice ("Invoice") must be submitted before payment will be made by District pursuant to this Order.

- a. PAYMENT OF FIXED PRICE CONTRACTS. Seller's Invoice will be paid by District not later than thirty (30) days following receipt to District.

3. SCHEDULE. Seller shall deliver the Goods per the schedule ("Schedule") and/or term ("Term") shown on Page 1 of this Order. Time is of the essence with respect to this Order, and Seller shall not deviate from the Schedule without District's prior written consent. District may cancel this Order or any part thereof or reject delivery of Goods if such delivery or performance is not in material accordance with the specifications of this Order, including the Schedule.

4. TERMS APPLICABLE TO THE PURCHASE OF GOODS.

- a. DELIVERY. On all deliveries of Goods, freight shall be prepaid by Seller, which amount is included in the lump sum not to exceed price, and risk of loss shall pass at the time such Goods are delivered at the Project and the Goods are accepted by District. The Delivery Date shall be the date provided by District to Seller in writing.
- b. WARRANTY. In addition to the specific warranties provided in the attached Exhibit A and any additional manufacturer warranties, Seller warrants that the title to Goods conveyed shall be good and that the transfer of the Goods shall be rightful. The Goods shall be free from any security interest or lien, and the Goods shall conform to the description herein stated and any specifications provided by District. Seller agrees to assist in administering all warranty claims with manufacturer. All Goods are subject to inspection by District before, upon, and within a reasonable time after delivery. Goods shall not be replaced without District's prior written instructions. Any acceptance by District shall not prevent District from later rejecting non-conforming Goods.

5. [RESERVED.]

6. COMPLIANCE WITH LAW. Seller agrees that at all times it will comply with all applicable federal, state, municipal and local laws, orders and regulations.

7. INDEMNITY. TO THE MAXIMUM EXTENT PERMITTED BY APPLICABLE LAW, SELLER (ON BEHALF OF ITSELF AND ANY SUBCONTRACTORS) AGREES TO FULLY INDEMNIFY, HOLD HARMLESS AND DEFEND THE INDEMNIFIED PARTIES FROM AND AGAINST ANY AND ALL CLAIMS, LOSSES, DAMAGES, FINES, CAUSES OF ACTION, SUITS AND LIABILITY OF EVERY KIND INCLUDING COURT COSTS AND ATTORNEYS' FEES FOR INJURY TO OR DEATH OF ANY PERSON, FOR DAMAGE TO ANY PROPERTY AND ALL OTHER DAMAGES (COLLECTIVELY, "DAMAGES") TO THE EXTENT CAUSED BY THE NEGLIGENT OR WILLFUL ACTS AND/OR OMISSIONS OF SELLER (EXPRESSLY EXCLUDING, HOWEVER, DAMAGES CAUSED BY DISTRICT'S OWN NEGLIGENCE). THE PROVISIONS OF THIS

SECTION 7 SHALL SURVIVE THE COMPLETION OR EARLIER TERMINATION OF THIS ORDER.

8. [RESERVED.]

9. DEFAULT. Upon any material default by Seller hereunder, District may, in addition to any other remedies available to District at law or in equity, cancel this Order without penalty or liability by written notice to Seller. Seller shall be liable to District for all expenses incurred by District due to such termination. Seller's obligations under this Section 9 shall survive any termination of this Order.

10. LIMITATION OF LIABILITY. Nothing herein shall be construed to be a waiver of the District's limit of liability contained in Section 768.28, *Florida Statutes*.

11. WAIVER. Any failure of District to enforce at any time, or for any period of time, any of the provisions of this Order shall not constitute a waiver of such provisions or a waiver of District's right to enforce each and every provision.

12. MODIFICATIONS. This Order supersedes all prior discussions, agreements and understandings between the parties and constitutes the entire agreement between the parties with respect to the transaction herein contemplated. Changes, modifications, waivers, additions or amendments to the terms and conditions of this Order shall be binding on District only if such changes, modifications, waivers, additions or amendments are in writing and signed by a duly authorized representative of District. If such changes result in a decrease or increase in Seller's cost or in performance time, an adjustment to the Price and Schedule must be made and agreed upon in writing by both District and Seller.

13. ATTACHMENTS. Any document referenced on Page 1 of this Order, including but not limited to Exhibit A attached hereto shall be for the sole purpose of providing a description of the Goods. Any quote attached as Exhibit A hereto shall be for the purpose of indicating the maximum price of the Goods and delivery totals. The terms of this Order shall be deemed to control over the terms of Exhibit A attached hereto.

14. APPLICABLE LAW. The validity, interpretation, and performance of this Order shall be governed by the laws of the State of Florida, in force at the date of this Order. Where not modified by the terms herein, the provisions of Florida's enactment of Article 2 of the Uniform Commercial Code shall apply to this transaction.

15. MECHANIC'S LIENS. Notwithstanding that District is a local unit of special purpose government and not subject to the lien provisions of Chapter 713, *Florida Statutes*, Seller agrees to keep the Project free of all liens, including equitable liens, claims or encumbrances (collectively, "Liens") arising out of the delivery of any Goods by Seller, and shall furnish District with appropriate lien waivers from all potential claimants upon request of District. If any Liens are filed, District may without waiving its rights based on such breach by Seller or releasing Seller from any obligations hereunder, pay or satisfy the same and in such event the sums so paid by District shall be due and payable by Seller immediately and without notice or demand. Seller shall indemnify and hold District harmless for all expenses incurred by District as a result of the failure of Seller to fulfill its obligations under this Section 15.

16. [RESERVED.]

17. PARTIAL INVALIDITY. If in any provision of this Order shall be determined to be invalid or unenforceable under any applicable law, such provision shall not apply in such instance, but the remaining provisions shall be given effect in accordance with their terms.

18. ASSIGNMENT AND SUBCONTRACTING. This Order shall not be assigned or transferred by Seller without prior written approval by District, and any attempted assignment or transfer without such consent shall be void. Seller shall not subcontract this Order without the prior written consent of District. District may assign this Order to any transferee of the Project with Seller's written approval.

19. RELATIONSHIP. The relationship between District and Seller shall be that of independent contractor, and Seller, its agents and employees, shall under no circumstances be deemed employees, agents or representatives of District. Seller agrees that District shall not be responsible for job-site safety or safety of Seller's agents or employees in connection with delivery of the Goods.

20. NOTICES. Any notice, approval or other communication required hereunder must be in writing and shall be deemed given if delivered by hand or mailed by registered mail or certified mail addressed to the parties hereto as indicated on Page 1.

21. TERMINATION OPTION. Notwithstanding anything herein to the contrary, District shall have the right, at its sole election, to terminate this Order for any cause whatsoever upon the delivery of written notice to Seller.

22. RELEASE OF INFORMATION. Seller acknowledges that this Agreement and all the documents pertaining thereto are public records and subject to the provisions of Chapter 119, *Florida Statutes*.

EXHIBIT A



Town Operations

DATE: 10/31/25
NAME: Somerset Community Development District c/o Rizzetta
LOCATION: E Sugar Lump @ RR2 (RR-1)
PROJECT: Street Light Replacement
ESTIMATED START DATE:
ESTIMATED COMPLETION DATE:

DESCRIPTION:
Replace T4 Street Light

MATERIALS:	
Street Light Pole and Fixture	\$5445.00
LABOR:	
SUBTOTAL:	
TAX:	
TOTAL:	5445.00

NAME:	DATE:
SIGNATURE:	
ABM NAME:	DATE:
ABM SIGNATURE:	

McHenry Electric

Proposal #: 25-190
Amount: \$ 2,350.00

WORK AUTHORIZATION FOR MAINTENANCE SERVICES – WA #26-07

This Work Authorization (the “**Work Authorization**”), dated December 1, 2025, authorizes certain work in accordance with that certain *AGREEMENT BETWEEN THE SOMERSET COMMUNITY DEVELOPMENT DISTRICT AND MCHENRY ELECTRIC, INC., FOR GENERAL MAINTENANCE SERVICES* (the “**Agreement**”), dated April 6, 2022, by and between:

SOMERSET COMMUNITY DEVELOPMENT DISTRICT, a local unit of special-purpose government established pursuant to Chapter 190, *Florida Statutes*, being situated in Walton County, Florida, and whose mailing address is 3434 Colwell Avenue, Suite 200, Tampa, Florida 33614 (the “**District**”); and

MCHENRY ELECTRIC, INC., a Florida for profit corporation, with a mailing address of 50 Hatchew Road, Miramar Beach, Florida 32550 (hereinafter “**Contractor**”, together with District the “**Parties**”).

Section 1. Scope of Services. Contractor shall provide repair and maintenance services, as set forth in the attached **Exhibit A**, which is incorporated herein by reference, all in accordance with the terms of the Agreement (collectively, the “**Services**”).

Section 2. Compensation and Term. It is understood and agreed that the payment of compensation for the Services under this Work Authorization shall be in the amount and for the term set forth in the attached **Exhibit A**, and in the manner set forth in the Agreement.

Section 3. Acceptance. Acceptance of this Work Authorization will authorize the Contractor to complete the Services as outlined above and is indicated by the signature of the authorized representative of the District and the Contractor in the spaces provided below. Contractor shall commence the aforesaid Services as provided herein and shall perform the same in accordance with the terms and conditions of the Agreement, which, except to the extent expressly altered or changed in this Work Authorization, remain in full force and effect.

IN WITNESS WHEREOF, the Parties hereto have caused this Work Authorization to be executed the day and year first above written.

Secretary/Assistant Secretary

Niki Carr
Niki Carr (Dec 1, 2025 12:07:12 CST)
Witness

SOMERSET COMMUNITY DEVELOPMENT DISTRICT

Robert Stenhammer
Robert Stenhammer (Dec 1, 2025 11:21:10 CST)

By: Robert Stenhammer
Its: Chairman

MCHENRY ELECTRIC, INC.

D. Clayton McHenry
D. Clayton McHenry (Dec 1, 2025 12:53:43 CST)

By: D. Clayton McHenry
Its: President

Exhibit A: Proposal/Scope of Services

<p>Proposal</p> <p>McHenry Electric, Inc</p> <p><small>*Proudly Serving the Emerald Coast Since 1988*</small></p> <p><small>5014 E. New Road Miramar Beach, FL 32550 (850) 837-9003 ER0008321</small></p>		
<p>No. 25-190</p>	<p>Phone: 850-334-9055</p>	<p>Date: November 10, 2025</p>
<p>Proposed Submitted to: Somerset CDO & Rizzetta & Company, Inc</p>	<p>Job Name: T-4 Streetlight</p>	
<p>Street: 3034 Colwell Ave Suite 200</p>	<p>Job Location: RR-01</p>	
<p>City, State and Zip code: Tampa, FL 33614</p>	<p>City, State and Zip code: Inlet Beach, FL 32461</p>	
<p>Architect: N/A</p>	<p>Date of Plan: N/A</p>	
<p>We propose hereby to furnish material and labor - complete in accordance with specification or below, for the sum of</p> <p>Two thousand three hundred fifty dollars and 00/100 ----- (\$2,350.00)</p>		
<p>Payment to be made as follows:</p> <p>Net 10 days. A finance charge of 1.5% per month (18% per annum) will be charged on all unpaid balances. 100% due upon completion.</p>		
<p>All work to be completed in a workmanlike manner according to standard practices. Any alterations or deviations from specifications below including extras will be executed upon written or oral orders and will become an extra charge of the above estimate. All agreements contingent upon strikes, accidents, or delays beyond our control. Owner to carry fire, tornado, and other necessary insurance. Our workers are fully covered by Workers' Compensation Insurance.</p>		<p>Authorized Signature: </p> <p>D. Clayton McHenry - President</p> <p><small>Note: This proposal may be withdrawn by us if not accepted within <u>3</u> days.</small></p>
<p>We hereby submit this specification and all therefor. <u>Remove and replace (1) owner furnished streetlight.</u></p> <p>Includes the following:</p>		
<p>A. Remove broken pole on East Sugar Lump Lane (RR-01).</p>		
<p>B. Remove concrete base.</p>		
<p>C. Store, assemble and install owner furnished T-4 light pole, light head, and light bulb.</p>		
<p>D. Furnish and install new wire to J box.</p>		
<p>E. Furnish and install ground sleeve and gravel.</p>		
<p>Does Not Include: any warranty, liability, responsibility for any existing electrical wiring, fixtures, Decora devices, lamps, LED lamps, plug strips, lightning protection, exterior light package, emergency lights, and generator, landscape lighting, automatic transfer switch, streetlight, pole, plants painting, or patching. All to be supplied by others.</p>		
<p>Accepted Proposal - The above prices, specifications, and conditions are both accepted and hereby accepted. You authorize to do the work as specified. Payment will be made as outlined above. NOTE: the above price is based on current material prices. If any material price increases over 5%, the above price will have to be adjusted. The above price is only valid for 3 days from the date above, if the job is not completed within 3 days, it might be necessary to adjust the contract price. Travelling party is due any legal fees arising from this contract. We reserve the right to accept work due to nonpayment of invoices.</p>		<p>Signature - _____</p> <p>Date of Acceptance _____</p>

Rip's Professional Lawn Care

FORM OF ADDITIONAL SERVICES ORDER

WORK AUTHORIZATION #26-03 FOR ADDITIONAL LANDSCAPE AND IRRIGATION MAINTENANCE SERVICES

THIS WORK AUTHORIZATION (the “**Work Authorization**”), dated December 17, 2025, authorizes certain work in accordance with that certain *Landscape and Irrigation Maintenance Services Agreement* (the “**Agreement**”), dated October 1, 2021, by and between:

SOMERSET COMMUNITY DEVELOPMENT DISTRICT, a local unit of special-purpose government established pursuant to Chapter 190, *Florida Statutes*, being situated in Walton County, Florida, and having offices at c/o Rizzetta & Company, Inc., 120 Richard Jackson Blvd., Suite 220, Panama City Beach, Florida 32407 (“**District**”); and

RIP’S PROFESSIONAL LAWN CARE, INC., a Florida corporation, with a mailing address of 511 North Highway 79, Panama City Beach, Florida 32413 (the “**Contractor**,” and collectively with the District, the “**Parties**”).

SECTION 1. SCOPE OF SERVICES. In addition to the Services described in the Agreement and any Exhibits and Amendments thereto, the Contractor will provide additional landscape and irrigation maintenance services, as set forth in the attached **Exhibit A**, which is incorporated herein by reference, all in accordance with the terms of the Agreement (collectively, the “**Additional Services**”).

SECTION 2. COMPENSATION. It is understood and agreed that the payment of compensation for the Additional Services under this Work Authorization shall be in the amount set forth in the attached **Exhibit A**, and in the manner set forth in the Agreement.

SECTION 3. ACCEPTANCE. Acceptance of this Work Authorization will authorize the Contractor to complete the Additional Services as outlined above and is indicated by the signature of the authorized representative of the District and the Contractor in the spaces provided below. Contractor shall commence the aforesaid Additional Services as provided herein and shall perform the same in accordance with the terms and conditions of the Agreement, which, except to the extent expressly altered or changed in this Work Authorization, remain in full force and effect.

[REMAINDER OF PAGE LEFT INTENTIONALLY BLANK]

IN WITNESS WHEREOF, the Parties hereto have caused this Work Authorization to be executed the day and year first above written.



Assistant Secretary

SOMERSET COMMUNITY DEVELOPMENT DISTRICT



Robert Stenhammer (Dec 17, 2025 12:20:55 CST)

Chairman, Board of Supervisors

Shannon Smith (Dec 17, 2025 12:59:02 CST)

Witness

RIP'S PROFESSIONAL LAWN CARE, INC.

BRIAN CALKINS (Dec 17, 2025 12:00:24 CST)

By: BRIAN CALKINS
Its: Branch Manager

Exhibit A: Proposal/Scope of Additional Services

Proposal

Proposal No.: 377668
Proposed Date: 12/16/25

PROPERTY:	FOR:
Somerset Community Development District Kim O'Mera 84 Elbow Beach Road Somerset Community Highway 30A Corridor Inlet Beach, FL 32461	Repair to main line riser West End by 30A

Repair broken water line from truck damage

ITEM	QTY	UOM	UNIT PRICE	EXT. PRICE	TOTAL
Irrigation Renovation					
Lateral Components					\$277.05
Irrigation Tech Labor	2.00	HR	\$75.00	\$150.00	
Misc Irrigation Parts	1.00	EA	\$8.95	\$8.95	
NDS Pro-Span PVC Expansion Repair Coupling 2-1/2 in. Socket x Spigot SLIP FIX	1.00	EA	\$86.45	\$86.45	
PVC Pipe 2 in. x 20 ft. Schedule 40 Bell End (Sold per ft.)	2.00	FT	\$2.85	\$5.70	
2-1/2 Tee Soc x Fipt PVC Fitting	1.00	EA	\$25.95	\$25.95	
				Total:	\$277.05

FORM OF ADDITIONAL SERVICES ORDER

WORK AUTHORIZATION #26-04 FOR ADDITIONAL LANDSCAPE AND IRRIGATION MAINTENANCE SERVICES

THIS WORK AUTHORIZATION (the “**Work Authorization**”), dated December 17, 2025, authorizes certain work in accordance with that certain *Landscape and Irrigation Maintenance Services Agreement* (the “**Agreement**”), dated October 1, 2021, by and between:

SOMERSET COMMUNITY DEVELOPMENT DISTRICT, a local unit of special-purpose government established pursuant to Chapter 190, *Florida Statutes*, being situated in Walton County, Florida, and having offices at c/o Rizzetta & Company, Inc., 120 Richard Jackson Blvd., Suite 220, Panama City Beach, Florida 32407 (“**District**”); and

RIP’S PROFESSIONAL LAWN CARE, INC., a Florida corporation, with a mailing address of 511 North Highway 79, Panama City Beach, Florida 32413 (the “**Contractor**,” and collectively with the District, the “**Parties**”).

SECTION 1. SCOPE OF SERVICES. In addition to the Services described in the Agreement and any Exhibits and Amendments thereto, the Contractor will provide additional landscape and irrigation maintenance services, as set forth in the attached **Exhibit A**, which is incorporated herein by reference, all in accordance with the terms of the Agreement (collectively, the “**Additional Services**”).

SECTION 2. COMPENSATION. It is understood and agreed that the payment of compensation for the Additional Services under this Work Authorization shall be in the amount set forth in the attached **Exhibit A**, and in the manner set forth in the Agreement.

SECTION 3. ACCEPTANCE. Acceptance of this Work Authorization will authorize the Contractor to complete the Additional Services as outlined above and is indicated by the signature of the authorized representative of the District and the Contractor in the spaces provided below. Contractor shall commence the aforesaid Additional Services as provided herein and shall perform the same in accordance with the terms and conditions of the Agreement, which, except to the extent expressly altered or changed in this Work Authorization, remain in full force and effect.

[REMAINDER OF PAGE LEFT INTENTIONALLY BLANK]

IN WITNESS WHEREOF, the Parties hereto have caused this Work Authorization to be executed the day and year first above written.

Kim O'Mera

Kim O'Mera (Dec 17, 2025 13:10:31 CST)

Assistant Secretary

SOMERSET COMMUNITY DEVELOPMENT DISTRICT

Robert Stenhammer

Robert Stenhammer (Dec 22, 2025 09:21:13 CST)

Chairman, Board of Supervisors

Shannon Smith

Shannon Smith (Dec 17, 2025 13:56:03 CST)

Witness

RIP'S PROFESSIONAL LAWN CARE, INC.

Brian Calkins

BRIAN CALKINS (Dec 17, 2025 13:25:28 CST)

By: **BRIAN CALKINS**

Its: **Branch manager**

Exhibit A: Proposal/Scope of Additional Services



Proposal

Proposal No.: 377608

Proposed Date: 12/16/25

PROPERTY:	FOR:
Somerset Community Development District Kim O'Mera 84 Elbow Beach Road-Somerset Community Highway 30A Corridor Inlet Beach, FL 32461	East Well 2-inch water High pressure meter replacement

East well is having pressure problems. Replace with new Sensen 2-inch-High pressure water meter. Includes new sleeve and gaskets

ITEM	QTY	UOM	TOTAL
Irrigation Renovation			
Lateral Components			\$3,509.00
Irrigation Tech Labor	2.00	HR	
Misc Irrigation Parts	4.00	EA	
2 inch Sensen High pressure flow meter with install kit	1.00	EA	
Total:			\$3,509.00

FORM OF ADDITIONAL SERVICES ORDER

**WORK AUTHORIZATION #26-06 FOR ADDITIONAL LANDSCAPE AND IRRIGATION
MAINTENANCE SERVICES**

THIS WORK AUTHORIZATION (the “**Work Authorization**”), dated December 29, 2025, authorizes certain work in accordance with that certain *Landscape and Irrigation Maintenance Services Agreement* (the “**Agreement**”), dated October 1, 2021, by and between:

SOMERSET COMMUNITY DEVELOPMENT DISTRICT, a local unit of special-purpose government established pursuant to Chapter 190, *Florida Statutes*, being situated in Walton County, Florida, and having offices at c/o Rizzetta & Company, Inc., 120 Richard Jackson Blvd., Suite 220, Panama City Beach, Florida 32407 (“**District**”); and

RIP’S PROFESSIONAL LAWN CARE, INC., a Florida corporation, with a mailing address of 511 North Highway 79, Panama City Beach, Florida 32413 (the “**Contractor**,” and collectively with the District, the “**Parties**”).

SECTION 1. SCOPE OF SERVICES. In addition to the Services described in the Agreement and any Exhibits and Amendments thereto, the Contractor will provide additional landscape and irrigation maintenance services, as set forth in the attached **Exhibit A**, which is incorporated herein by reference, all in accordance with the terms of the Agreement (collectively, the “**Additional Services**”).

SECTION 2. COMPENSATION. It is understood and agreed that the payment of compensation for the Additional Services under this Work Authorization shall be in the amount set forth in the attached **Exhibit A**, and in the manner set forth in the Agreement.

SECTION 3. ACCEPTANCE. Acceptance of this Work Authorization will authorize the Contractor to complete the Additional Services as outlined above and is indicated by the signature of the authorized representative of the District and the Contractor in the spaces provided below. Contractor shall commence the aforesaid Additional Services as provided herein and shall perform the same in accordance with the terms and conditions of the Agreement, which, except to the extent expressly altered or changed in this Work Authorization, remain in full force and effect.

[REMAINDER OF PAGE LEFT INTENTIONALLY BLANK]

IN WITNESS WHEREOF, the Parties hereto have caused this Work Authorization to be executed the day and year first above written.

Assistant Secretary

SOMERSET COMMUNITY DEVELOPMENT DISTRICT

Robert Stenhammer (Jan 8, 2026 16:29:17 CST)
Chairman, Board of Supervisors

Shannon Smith (Jan 9, 2026 08:08:10 CST)
Witness

RIP'S PROFESSIONAL LAWN CARE, INC.



Brian Calkins (Jan 8, 2026 16:35:31 CST)
By: BRIAN CALKINS
Its: Branch Manager

Exhibit A: Proposal/Scope of Additional Services

Item	Qty/UOM	Rate	Ext. Price	Amount
#378622 - Repair to main line near East Well.				\$632.58
<i>Lateral Components - 12/29/2025</i>				
Irrigation Tech Labor	4.00HR	\$75.00	\$300.00	
Misc Irrigation Parts	2.00EA	\$13.65	\$27.30	
NDS FloControl Series 1011 Spring Check Valve PVC 2 in. Slip 1/2# Spring	1.00EA	\$125.88	\$125.88	
NDS Pro-Span PVC Expansion Repair Coupling 2-1/2 in. Socket x Spigot SLIP FIX	1.00EA	\$86.45	\$86.45	
Pipe Sch 40 PVC 2-1/2 in.	2.00EA	\$33.50	\$67.00	
2-1/2 in. x 2 in. PVC Reducing Tee Soc x Fpt	1.00EA	\$25.95	\$25.95	
			Grand Total	\$632.58

FORM OF ADDITIONAL SERVICES ORDER

WORK AUTHORIZATION #26-07 FOR ADDITIONAL LANDSCAPE AND IRRIGATION MAINTENANCE SERVICES

THIS WORK AUTHORIZATION (the “**Work Authorization**”), dated December 23, 2025, authorizes certain work in accordance with that certain *Landscape and Irrigation Maintenance Services Agreement* (the “**Agreement**”), dated October 1, 2021, by and between:

SOMERSET COMMUNITY DEVELOPMENT DISTRICT, a local unit of special-purpose government established pursuant to Chapter 190, *Florida Statutes*, being situated in Walton County, Florida, and having offices at c/o Rizzetta & Company, Inc., 120 Richard Jackson Blvd., Suite 220, Panama City Beach, Florida 32407 (“**District**”); and

RIP’S PROFESSIONAL LAWN CARE, INC., a Florida corporation, with a mailing address of 511 North Highway 79, Panama City Beach, Florida 32413 (the “**Contractor**,” and collectively with the District, the “**Parties**”).

SECTION 1. SCOPE OF SERVICES. In addition to the Services described in the Agreement and any Exhibits and Amendments thereto, the Contractor will provide additional landscape and irrigation maintenance services, as set forth in the attached **Exhibit A**, which is incorporated herein by reference, all in accordance with the terms of the Agreement (collectively, the “**Additional Services**”).

SECTION 2. COMPENSATION. It is understood and agreed that the payment of compensation for the Additional Services under this Work Authorization shall be in the amount set forth in the attached **Exhibit A**, and in the manner set forth in the Agreement.

SECTION 3. ACCEPTANCE. Acceptance of this Work Authorization will authorize the Contractor to complete the Additional Services as outlined above and is indicated by the signature of the authorized representative of the District and the Contractor in the spaces provided below. Contractor shall commence the aforesaid Additional Services as provided herein and shall perform the same in accordance with the terms and conditions of the Agreement, which, except to the extent expressly altered or changed in this Work Authorization, remain in full force and effect.

[REMAINDER OF PAGE LEFT INTENTIONALLY BLANK]

IN WITNESS WHEREOF, the Parties hereto have caused this Work Authorization to be executed the day and year first above written.

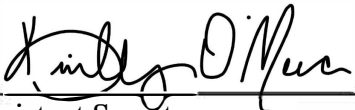

Assistant Secretary

SOMERSET COMMUNITY DEVELOPMENT DISTRICT



Robert Stenhammer (Jan 8, 2026 16:28:52 CST)

Chairman, Board of Supervisors

Shannon Smith (Jan 9, 2026 08:06:50 CST)

Witness

RIP'S PROFESSIONAL LAWN CARE, INC.

Brian Calkins (Jan 8, 2026 16:36:00 CST)

By: BRIAN CALKINS
Its: Branch Manager

Exhibit A: Proposal/Scope of Additional Services

Item	Qty/UOM	Rate	Ext. Price	Amount
#378380 - Repair 8 inch main line near Hoover.				\$285.00
<i>Pine Straw - 12/23/2025</i>				
Enhancement Labor	3.00HR	\$75.00	\$225.00	
Pine straw (Roll)	2.00Roll	\$30.00	\$60.00	
			Grand Total	\$285.00

#378125 - Repair 8 inch main line near Hoover.				\$3,599.50
<i>Lateral Components - 12/23/2025</i>				
Irrigation Tech Labor	32.00HR	\$75.00	\$2,400.00	
Misc Irrigation Parts	1.00EA	\$14.00	\$14.00	
Megalug Mechanical Joint Stargrip 3000	2.00EA	\$167.80	\$335.60	
Ductile Iron 8 in. w/ Accessories				
PVC Pipe 8 in. x 20 ft. Schedule 80 Plain End (Sold per ft.)	3.00FT	\$99.00	\$297.00	
Mega Lug 90 Degree Elbow 8 inch	1.00EA	\$345.00	\$345.00	
1 inch conduit grey flex line	5.00EA	\$27.88	\$139.40	
Plywood	1.00EA	\$68.50	\$68.50	
			Grand Total	\$3,599.50

Total: \$3,884.50

FORM OF ADDITIONAL SERVICES ORDER

WORK AUTHORIZATION #26-08 FOR ADDITIONAL LANDSCAPE AND IRRIGATION MAINTENANCE SERVICES

THIS WORK AUTHORIZATION (the “**Work Authorization**”), dated January 6, 2026, authorizes certain work in accordance with that certain *Landscape and Irrigation Maintenance Services Agreement* (the “**Agreement**”), dated October 1, 2021, by and between:

SOMERSET COMMUNITY DEVELOPMENT DISTRICT, a local unit of special-purpose government established pursuant to Chapter 190, *Florida Statutes*, being situated in Walton County, Florida, and having offices at c/o Rizzetta & Company, Inc., 120 Richard Jackson Blvd., Suite 220, Panama City Beach, Florida 32407 (“**District**”); and

RIP’S PROFESSIONAL LAWN CARE, INC., a Florida corporation, with a mailing address of 511 North Highway 79, Panama City Beach, Florida 32413 (the “**Contractor**,” and collectively with the District, the “**Parties**”).

SECTION 1. SCOPE OF SERVICES. In addition to the Services described in the Agreement and any Exhibits and Amendments thereto, the Contractor will provide additional landscape and irrigation maintenance services, as set forth in the attached **Exhibit A**, which is incorporated herein by reference, all in accordance with the terms of the Agreement (collectively, the “**Additional Services**”).

SECTION 2. COMPENSATION. It is understood and agreed that the payment of compensation for the Additional Services under this Work Authorization shall be in the amount set forth in the attached **Exhibit A**, and in the manner set forth in the Agreement.

SECTION 3. ACCEPTANCE. Acceptance of this Work Authorization will authorize the Contractor to complete the Additional Services as outlined above and is indicated by the signature of the authorized representative of the District and the Contractor in the spaces provided below. Contractor shall commence the aforesaid Additional Services as provided herein and shall perform the same in accordance with the terms and conditions of the Agreement, which, except to the extent expressly altered or changed in this Work Authorization, remain in full force and effect.

[REMAINDER OF PAGE LEFT INTENTIONALLY BLANK]

IN WITNESS WHEREOF, the Parties hereto have caused this Work Authorization to be executed the day and year first above written.

Assistant

SOMERSET COMMUNITY DEVELOPMENT DISTRICT

Robert Stenhammer
Robert Stenhammer (Jan 8, 2026 16:28:26 CST)
Chairman, Board of Supervisors

Shannon Smith
Shannon Smith (Jan 9, 2026 08:04:48 CST)
Witness

RIP'S PROFESSIONAL LAWN CARE, INC.

Brian Calkins
Brian Calkins (Jan 8, 2026 16:36:56 CST)
By: BRIAN CALKINS
Its: Branch Manager

Exhibit A: Proposal/Scope of Additional Services

Item	Qty/UOM	Rate	Ext. Price	Amount
#376485 - Irrigation repair main line P18 roadside				\$264.75
<i>Lateral Components - 12/10/2025</i>				
Irrigation Tech Labor	2.00HR	\$75.00	\$150.00	
Misc Irrigation Parts	2.00EA	\$6.85	\$13.70	
NDS Pro-Span PVC Expansion Repair Coupling 2-1/2 in. Socket x Spigot SLIP FIX	1.00EA	\$6.55	\$6.55	
PVC Pipe 2 1/2 in. x 20 ft. Schedule 40 Bell End (Sold per ft.)	2.00FT	\$7.25	\$14.50	
			Grand Total	\$264.75

FORM OF ADDITIONAL SERVICES ORDER

WORK AUTHORIZATION #26-09 FOR ADDITIONAL LANDSCAPE AND IRRIGATION MAINTENANCE SERVICES

THIS WORK AUTHORIZATION (the “**Work Authorization**”), dated December 18, 2025, authorizes certain work in accordance with that certain *Landscape and Irrigation Maintenance Services Agreement* (the “**Agreement**”), dated October 1, 2021, by and between:

SOMERSET COMMUNITY DEVELOPMENT DISTRICT, a local unit of special-purpose government established pursuant to Chapter 190, *Florida Statutes*, being situated in Walton County, Florida, and having offices at c/o Rizzetta & Company, Inc., 120 Richard Jackson Blvd., Suite 220, Panama City Beach, Florida 32407 (“**District**”); and

RIP’S PROFESSIONAL LAWN CARE, INC., a Florida corporation, with a mailing address of 511 North Highway 79, Panama City Beach, Florida 32413 (the “**Contractor**,” and collectively with the District, the “**Parties**”).

SECTION 1. SCOPE OF SERVICES. In addition to the Services described in the Agreement and any Exhibits and Amendments thereto, the Contractor will provide additional landscape and irrigation maintenance services, as set forth in the attached **Exhibit A**, which is incorporated herein by reference, all in accordance with the terms of the Agreement (collectively, the “**Additional Services**”).

SECTION 2. COMPENSATION. It is understood and agreed that the payment of compensation for the Additional Services under this Work Authorization shall be in the amount set forth in the attached **Exhibit A**, and in the manner set forth in the Agreement.

SECTION 3. ACCEPTANCE. Acceptance of this Work Authorization will authorize the Contractor to complete the Additional Services as outlined above and is indicated by the signature of the authorized representative of the District and the Contractor in the spaces provided below. Contractor shall commence the aforesaid Additional Services as provided herein and shall perform the same in accordance with the terms and conditions of the Agreement, which, except to the extent expressly altered or changed in this Work Authorization, remain in full force and effect.

[REMAINDER OF PAGE LEFT INTENTIONALLY BLANK]

IN WITNESS WHEREOF, the Parties hereto have caused this Work Authorization to be executed the day and year first above written.

Assistant Secretary

SOMERSET COMMUNITY DEVELOPMENT DISTRICT

Robert Stenhammer (Jan 9, 2026 10:54:08 CST)
Chairman, Board of Supervisors

Shannon Smith (Jan 9, 2026 08:52:34 CST)
Witness

RIP'S PROFESSIONAL LAWN CARE, INC.



Brian Calkins (Jan 9, 2026 09:12:50 CST)
By: BRIAN CALKINS
Its: Branch Manager

Exhibit A: Proposal/Scope of Additional Services

Item	Qty/UOM	Rate	Ext. Price	Amount
#376675 - Installation of Centralus Irrigation monitoring system				\$4,439.60
<i>Control Components - 12/18/2025</i>				
Irrigation Tech Labor	2.00HR	\$60.00	\$120.00	
Centralus Hunter A2CLTEM Link Connection Module and system loop	4.00EA	\$912.50	\$3,650.00	
Annual Cellular Link Fee	4.00EA	\$167.40	\$669.60	
			Grand Total	\$4,439.60

FORM OF ADDITIONAL SERVICES ORDER

WORK AUTHORIZATION #26-10 FOR ADDITIONAL LANDSCAPE AND IRRIGATION MAINTENANCE SERVICES

THIS WORK AUTHORIZATION (the “**Work Authorization**”), dated December 23, 2025, authorizes certain work in accordance with that certain *Landscape and Irrigation Maintenance Services Agreement* (the “**Agreement**”), dated October 1, 2021, by and between:

SOMERSET COMMUNITY DEVELOPMENT DISTRICT, a local unit of special-purpose government established pursuant to Chapter 190, *Florida Statutes*, being situated in Walton County, Florida, and having offices at c/o Rizzetta & Company, Inc., 120 Richard Jackson Blvd., Suite 220, Panama City Beach, Florida 32407 (“**District**”); and

RIP’S PROFESSIONAL LAWN CARE, INC., a Florida corporation, with a mailing address of 511 North Highway 79, Panama City Beach, Florida 32413 (the “**Contractor**,” and collectively with the District, the “**Parties**”).

SECTION 1. SCOPE OF SERVICES. In addition to the Services described in the Agreement and any Exhibits and Amendments thereto, the Contractor will provide additional landscape and irrigation maintenance services, as set forth in the attached **Exhibit A**, which is incorporated herein by reference, all in accordance with the terms of the Agreement (collectively, the “**Additional Services**”).

SECTION 2. COMPENSATION. It is understood and agreed that the payment of compensation for the Additional Services under this Work Authorization shall be in the amount set forth in the attached **Exhibit A**, and in the manner set forth in the Agreement.

SECTION 3. ACCEPTANCE. Acceptance of this Work Authorization will authorize the Contractor to complete the Additional Services as outlined above and is indicated by the signature of the authorized representative of the District and the Contractor in the spaces provided below. Contractor shall commence the aforesaid Additional Services as provided herein and shall perform the same in accordance with the terms and conditions of the Agreement, which, except to the extent expressly altered or changed in this Work Authorization, remain in full force and effect.

[REMAINDER OF PAGE LEFT INTENTIONALLY BLANK]

IN WITNESS WHEREOF, the Parties hereto have caused this Work Authorization to be executed the day and year first above written.

Assistant Secretary

SOMERSET COMMUNITY DEVELOPMENT DISTRICT

Robert Stenhammer (Jan 8, 2026 16:27:58 CST)
Chairman, Board of Supervisors

Shannon Smith (Jan 9, 2026 08:03:24 CST)
Witness

RIP'S PROFESSIONAL LAWN CARE, INC.



Brian Calkins (Jan 8, 2026 16:37:52 CST)
By: BRIAN CALKINS
Its: BRANCH MANAGER

Exhibit A: Proposal/Scope of Additional Services

Item	Qty/UOM	Rate	Ext. Price	Amount
#376227 - Irrigation main line 30A in front of Neat				\$778.67
<i>Lateral Components - 12/10/2025</i>				
Irrigation Tech Labor	6.00HR	\$75.00	\$450.00	
Misc Irrigation Parts and supplies from shop	1.00EA	\$38.88	\$38.88	
PVC Pipe 2 1/2 in. x 20 ft. Schedule 40 Bell End (Sold per ft.)	10.00FF	\$7.25	\$72.50	
NDS Pro-Span PVC Expansion Repair Coupling 2-1/2 in. Socket x Spigot SLIP FIX	2.00EA	\$86.55	\$173.10	
NDS Pro-Span PVC Expansion Repair Coupling 1 in. Socket x Spigot SLIP FIX	1.00EA	\$35.58	\$35.58	
12/2 Maxi P70720 Black wire (Black Wire)	3.00EA	\$2.87	\$8.61	
			Grand Total	\$778.67

	31-60 Days	61-90 Days	91-120 Days	121+ Days
--	------------	------------	-------------	-----------

FORM OF ADDITIONAL SERVICES ORDER

WORK AUTHORIZATION #26-11 FOR ADDITIONAL LANDSCAPE AND IRRIGATION MAINTENANCE SERVICES

THIS WORK AUTHORIZATION (the “**Work Authorization**”), dated December 23, 2025, authorizes certain work in accordance with that certain *Landscape and Irrigation Maintenance Services Agreement* (the “**Agreement**”), dated October 1, 2021, by and between:

SOMERSET COMMUNITY DEVELOPMENT DISTRICT, a local unit of special-purpose government established pursuant to Chapter 190, *Florida Statutes*, being situated in Walton County, Florida, and having offices at c/o Rizzetta & Company, Inc., 120 Richard Jackson Blvd., Suite 220, Panama City Beach, Florida 32407 (“**District**”); and

RIP’S PROFESSIONAL LAWN CARE, INC., a Florida corporation, with a mailing address of 511 North Highway 79, Panama City Beach, Florida 32413 (the “**Contractor**,” and collectively with the District, the “**Parties**”).

SECTION 1. SCOPE OF SERVICES. In addition to the Services described in the Agreement and any Exhibits and Amendments thereto, the Contractor will provide additional landscape and irrigation maintenance services, as set forth in the attached **Exhibit A**, which is incorporated herein by reference, all in accordance with the terms of the Agreement (collectively, the “**Additional Services**”).

SECTION 2. COMPENSATION. It is understood and agreed that the payment of compensation for the Additional Services under this Work Authorization shall be in the amount set forth in the attached **Exhibit A**, and in the manner set forth in the Agreement.

SECTION 3. ACCEPTANCE. Acceptance of this Work Authorization will authorize the Contractor to complete the Additional Services as outlined above and is indicated by the signature of the authorized representative of the District and the Contractor in the spaces provided below. Contractor shall commence the aforesaid Additional Services as provided herein and shall perform the same in accordance with the terms and conditions of the Agreement, which, except to the extent expressly altered or changed in this Work Authorization, remain in full force and effect.

[REMAINDER OF PAGE LEFT INTENTIONALLY BLANK]

IN WITNESS WHEREOF, the Parties hereto have caused this Work Authorization to be executed the day and year first above written.



Assistant Secretary

SOMERSET COMMUNITY DEVELOPMENT DISTRICT
Robert Stenhammer
Robert Stenhammer (Jan 16, 2026 14:03:14 CST)

Chairman, Board of Supervisors

Shannon Smith
Shannon Smith (Jan 16, 2026 14:33:13 CST)

Witness

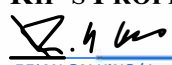
RIP'S PROFESSIONAL LAWN CARE, INC.

BRIAN CALKINS (Jan 16, 2026 15:21:09 CST)

By: **BRIAN CALKINS**

Its: **Branch Manager**

Exhibit A: Proposal/Scope of Additional Services

Item	Qty/UOM	Rate	Ext. Price	Amount
#376027 - Repair main line Silva at Whitten Way				\$447.65
<i>Lateral Components - 12/01/2025</i>				
Irrigation Tech Labor	2.50HR	\$75.00	\$187.50	
NDS Pro-Span PVC Expansion Repair Coupling 2-1/2 in. Socket x Spigot SLIP FIX	1.00EA	\$89.91	\$89.91	
2 inch Schedule 40 Irrigation pipe by the foot	5.00FT	\$13.44	\$67.20	
2-inch Misc Irrigation Fittings	10.00EA	\$10.30	\$103.04	
			Grand Total	\$447.65

FORM OF ADDITIONAL SERVICES ORDER

WORK AUTHORIZATION #26-12 FOR ADDITIONAL LANDSCAPE AND IRRIGATION MAINTENANCE SERVICES

THIS WORK AUTHORIZATION (the “**Work Authorization**”), dated December 23, 2025, authorizes certain work in accordance with that certain *Landscape and Irrigation Maintenance Services Agreement* (the “**Agreement**”), dated October 1, 2021, by and between:

SOMERSET COMMUNITY DEVELOPMENT DISTRICT, a local unit of special-purpose government established pursuant to Chapter 190, *Florida Statutes*, being situated in Walton County, Florida, and having offices at c/o Rizzetta & Company, Inc., 120 Richard Jackson Blvd., Suite 220, Panama City Beach, Florida 32407 (“**District**”); and

RIP’S PROFESSIONAL LAWN CARE, INC., a Florida corporation, with a mailing address of 511 North Highway 79, Panama City Beach, Florida 32413 (the “**Contractor**,” and collectively with the District, the “**Parties**”).

SECTION 1. SCOPE OF SERVICES. In addition to the Services described in the Agreement and any Exhibits and Amendments thereto, the Contractor will provide additional landscape and irrigation maintenance services, as set forth in the attached **Exhibit A**, which is incorporated herein by reference, all in accordance with the terms of the Agreement (collectively, the “**Additional Services**”).

SECTION 2. COMPENSATION. It is understood and agreed that the payment of compensation for the Additional Services under this Work Authorization shall be in the amount set forth in the attached **Exhibit A**, and in the manner set forth in the Agreement.

SECTION 3. ACCEPTANCE. Acceptance of this Work Authorization will authorize the Contractor to complete the Additional Services as outlined above and is indicated by the signature of the authorized representative of the District and the Contractor in the spaces provided below. Contractor shall commence the aforesaid Additional Services as provided herein and shall perform the same in accordance with the terms and conditions of the Agreement, which, except to the extent expressly altered or changed in this Work Authorization, remain in full force and effect.

[REMAINDER OF PAGE LEFT INTENTIONALLY BLANK]

IN WITNESS WHEREOF, the Parties hereto have caused this Work Authorization to be executed the day and year first above written.

Assistant Secretary

SOMERSET COMMUNITY DEVELOPMENT DISTRICT
Robert Stenhammer
Robert Stenhammer (Jan 16, 2026 14:02:40 CST)
Chairman, Board of Supervisors

Shannon Smith
Shannon Smith (Jan 16, 2026 14:32:43 CST)
Witness

RIP'S PROFESSIONAL LAWN CARE, INC.

BRIAN CALKINS (Jan 16, 2026 15:21:46 CST)
By: **BRIAN CALKINS**
Branch Manager
Its: _____

Exhibit A: Proposal/Scope of Additional Services

Item	Qty/UOM	Rate	Ext. Price	Amount
#376030 - Completed Irrigation Repairs - Silva Common Whitten Way				\$366.34
<i>Lateral Components - 12/01/2025</i>				
2" - 2.5" Misc Fittings Installed	7.00EA	\$43.06	\$301.44	
PVC Pipe 2" - 2.5" - sch 40 by the foot Installed	1.00FT	\$64.90	\$64.90	
			Grand Total	\$366.34

FORM OF ADDITIONAL SERVICES ORDER

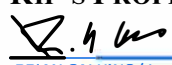
WORK AUTHORIZATION #26-13 FOR ADDITIONAL LANDSCAPE AND IRRIGATION MAINTENANCE SERVICES

THIS WORK AUTHORIZATION (the “**Work Authorization**”), dated December 31, 2025, authorizes certain work in accordance with that certain *Landscape and Irrigation Maintenance Services Agreement* (the “**Agreement**”), dated October 1, 2021, by and between:

SOMERSET COMMUNITY DEVELOPMENT DISTRICT, a local unit of special-purpose government established pursuant to Chapter 190, *Florida Statutes*, being situated in Walton County, Florida, and having offices at c/o Rizzetta & Company, Inc., 120 Richard Jackson Blvd., Suite 220, Panama City Beach, Florida 32407 (“**District**”); and

RIP’S PROFESSIONAL LAWN CARE, INC., a Florida corporation, with a mailing address of 511 North Highway 79, Panama City Beach, Florida 32413 (the “**Contractor**,” and collectively with the District, the “**Parties**”).

SECTION 1. SCOPE OF SERVICES. In addition to the Services described in the Agreement and any Exhibits and Amendments thereto, the Contractor will provide additional landscape and irrigation maintenance services, as set forth in the attached **Exhibit A**, which is incorporated herein by reference, all in accordance with the terms of the Agreement (collectively, the “**Additional Services**”).

SECTION 2. COMPENSATION. It is understood and agreed that the payment of compensation for the Additional Services under this Work Authorization shall be in the amount set forth in the attached **Exhibit A**, and in the manner set forth in the Agreement.

SECTION 3. ACCEPTANCE. Acceptance of this Work Authorization will authorize the Contractor to complete the Additional Services as outlined above and is indicated by the signature of the authorized representative of the District and the Contractor in the spaces provided below. Contractor shall commence the aforesaid Additional Services as provided herein and shall perform the same in accordance with the terms and conditions of the Agreement, which, except to the extent expressly altered or changed in this Work Authorization, remain in full force and effect.

[REMAINDER OF PAGE LEFT INTENTIONALLY BLANK]

IN WITNESS WHEREOF, the Parties hereto have caused this Work Authorization to be executed the day and year first above written.



Kim O'Neil (Jan 16, 2026 16:07:17 CST)

Assistant Secretary

SOMERSET COMMUNITY DEVELOPMENT DISTRICT



Robert Stenhammer (Jan 16, 2026 14:04:43 CST)

Chairman, Board of Supervisors



Shannon Smith (Jan 16, 2026 14:32:19 CST)

Witness

RIP'S PROFESSIONAL LAWN CARE, INC.

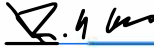

BRIAN CALKINS (Jan 16, 2026 15:22:43 CST)

By: BRIAN CALKINS

Its: Branch Manager

Exhibit A: Proposal/Scope of Additional Services

Item	Qty/UOM	Rate	Ext. Price	Amount
#377786 - Repair damage to 30A turf by East Buttery WA#26-05				\$2,617.19
<i>Landscape Material - 12/23/2025</i>				
Enhancement Labor	18.00HR	\$75.00	\$1,350.00	
Envirofill #12-20 Landscape Application	1.50BG	\$169.83	\$254.75	
Green Infill Sand 50 lb. Bag (62 bags/pallet)				
Latitude 36 Bermuda, 01 Square Foot	450.00Sq. Ft.	\$1.83	\$824.94	
Sod Cutter	2.00EA	\$93.75	\$187.50	
			Grand Total	\$2,617.19

Exhibit B: Voided, Previous Proposal

FORM OF ADDITIONAL SERVICES ORDER

WORK AUTHORIZATION #26-05 FOR ADDITIONAL LANDSCAPE AND IRRIGATION MAINTENANCE SERVICES

THIS WORK AUTHORIZATION (the “**Work Authorization**”), dated December 17, 2025, authorizes certain work in accordance with that certain *Landscape and Irrigation Maintenance Services Agreement* (the “**Agreement**”), dated October 1, 2021, by and between:

SOMERSET COMMUNITY DEVELOPMENT DISTRICT, a local unit of special-purpose government established pursuant to Chapter 190, *Florida Statutes*, being situated in Walton County, Florida, and having offices at c/o Rizzetta & Company, Inc., 120 Richard Jackson Blvd., Suite 220, Panama City Beach, Florida 32407 (“**District**”); and

RIP’S PROFESSIONAL LAWN CARE, INC., a Florida corporation, with a mailing address of 511 North Highway 79, Panama City Beach, Florida 32413 (the “**Contractor**,” and collectively with the District, the “**Parties**”).

SECTION 1. SCOPE OF SERVICES. In addition to the Services described in the Agreement and any Exhibits and Amendments thereto, the Contractor will provide additional landscape and irrigation maintenance services, as set forth in the attached **Exhibit A**, which is incorporated herein by reference, all in accordance with the terms of the Agreement (collectively, the “**Additional Services**”).

SECTION 2. COMPENSATION. It is understood and agreed that the payment of compensation for the Additional Services under this Work Authorization shall be in the amount set forth in the attached **Exhibit A**, and in the manner set forth in the Agreement.

SECTION 3. ACCEPTANCE. Acceptance of this Work Authorization will authorize the Contractor to complete the Additional Services as outlined above and is indicated by the signature of the authorized representative of the District and the Contractor in the spaces provided below. Contractor shall commence the aforesaid Additional Services as provided herein and shall perform the same in accordance with the terms and conditions of the Agreement, which, except to the extent expressly altered or changed in this Work Authorization, remain in full force and effect.

[REMAINDER OF PAGE LEFT INTENTIONALLY BLANK]

IN WITNESS WHEREOF, the Parties hereto have caused this Work Authorization to be executed the day and year first above written.

SOMERSET COMMUNITY DEVELOPMENT DISTRICT

09:31:03 CST

Assistant Secretary

Robert Stenhammer (Dec 22, 2025 09:20:12 CST)

Chairman, Board of Supervisors

Shannon Smith

Shannon Smith (Dec 17, 2025 13:57:20 CST)

Witness

RIP'S PROFESSIONAL LAWYER CARE, INC.

BRIAN CALKINS (Dec 17, 2025 13:26:17 CST)

By: BRIAN CALKINS

Its: Branch manager

VOIDED
Replaced by WIA #25-13

Exhibit A: Proposal/Scope of Additional Services

Juniper

Proposal

Proposal No.: 377786

Proposed Date: 12/17/25

PROPERTY:	FOR:
Somerset Community Development District Kim O'Mera 84 Elbow Beach Road-Somerset Community Highway 30A Corridor Inlet Beach, FL 32461	Repair damage to 30A turf by East Buttery

Repair turf damaged by car or truck driving on lawn

ITEM	QTY	UOM	TOTAL
Repair lawn along 30A where damage from car occurred. Will be T&M and may include irrigation repairs if needed.			
Landscape Material			\$1,605.62
Enhancement Labor	12.00	HR	
Envirofill #12-20 Landscape Application Green Infill Sand 50 lb. Bag (62 bags/pallet)	1.50	BG	
Latitude 36 Bermuda, 01 Square Foot	200.00	Sq. Ft.	
Postcard Bermudagrass (Coated) 25 lb.	0.10	EA	
Total:			\$1,605.62











2025-12-17 - Somerset CDD - WA #26-05 - Turn Repair 30A - Rip's Professional Lawn Care - Unexecuted

Final Audit Report

2025-12-22

Created:	2025-12-17
By:	Stephen Theriot (STheriot@rizzetta.com)
Status:	Signed
Transaction ID:	CBJCHBCAABAawOkIGmFIAQ0V9kItNXCOwOpea5G2FvP

"2025-12-17 - Somerset CDD - WA #26-05 - Turn Repair 30A - Rip's Professional Lawn Care - Unexecuted" History

-  Document created by Stephen Theriot (STheriot@rizzetta.com)
2025-12-17 - 6:59:15 PM GMT
-  Document emailed to Kim Komera (komera@rizzetta.com) for signature
2025-12-17 - 7:00:24 PM GMT
-  Document emailed to robert@oysbeach.com for signature
2025-12-17 - 7:00:24 PM GMT
-  Document emailed to BRIAN CALKINS (brian.calkins@juniperlandscaping.com) for signature
2025-12-17 - 7:00:24 PM GMT
-  Document emailed to Shannon Smith (shannon.smith@juniperlandscaping.com) for signature
2025-12-17 - 7:00:25 PM GMT
-  Email viewed by Kim Komera (komera@rizzetta.com)
2025-12-17 - 7:00:25 PM GMT
-  Email viewed by BRIAN CALKINS (brian.calkins@juniperlandscaping.com)
2025-12-17 - 7:25:46 PM GMT
-  Document e-signed by BRIAN CALKINS (brian.calkins@juniperlandscaping.com)
Signature Date: 2025-12-17 - 7:26:17 PM GMT - Time Source: server
-  Email viewed by Shannon Smith (shannon.smith@juniperlandscaping.com)
2025-12-17 - 7:56:51 PM GMT

 Document e-signed by Shannon Smith (shannon.smith@juniperlandscaping.com)

Signature Date: 2025-12-17 - 7:57:20 PM GMT - Time Source: server

 Document e-signed by Kim O'Mera (komera@rizzetta.com)

Signature Date: 2025-12-18 - 3:31:03 PM GMT - Time Source: server

 Email viewed by robert@alysbeach.com

2025-12-22 - 3:19:04 PM GMT

 Signer robert@alysbeach.com entered name at signing as Robert Stenhammer

2025-12-22 - 3:20:10 PM GMT

 Document e-signed by Robert Stenhammer (robert@alysbeach.com)

Signature Date: 2025-12-22 - 3:20:12 PM GMT - Time Source: server

 Agreement completed.

2025-12-22 - 3:20:12 PM GMT

VOIDED
Replaced by WA #25-13

Juniper Landscaping of Florida

**WORK AUTHORIZATION NUMBER 26-02
FOR ADDITIONAL SERVICES**

THIS WORK AUTHORIZATION (“Work Authorization”), dated January 6, 2026, authorizes certain work in accordance with that certain *Landscape and Irrigation Maintenance Services Agreement*, effective January 1, 2026 (the “**Agreement**”), by and between:

SOMERSET COMMUNITY DEVELOPMENT DISTRICT, a local unit of special-purpose government established pursuant to Chapter 190, *Florida Statutes*, located in Walton County, Florida (the “**District**”), and

JUNIPER LANDSCAPING OF FLORIDA LLC, a Florida limited liability company, with an address of 511 N. Highway 79, Panama City Beach, Florida 32413 (“**Contractor**”).

SECTION 1. SCOPE OF SERVICES. In addition to the services described in the Agreement and any exhibits, amendments and addenda thereto, Contractor shall provide stone replacement services, as set forth in the attached **Exhibit A**, which is incorporated herein by reference, all in accordance with the terms of the Agreement (collectively, the “**Additional Services**”). To the extent that the terms of **Exhibit A** conflict with terms of this Work Authorization or the Agreement, the Work Authorization and the Agreement shall control.

SECTION 2. COMPENSATION. As compensation for the Additional Services, the District agrees to pay Contractor **Fifty-Seven Thousand Six Hundred Forty-Eight Dollars (\$57,648.00)** due in full upon completion and acceptance of the Additional Services by the District.

SECTION 3. ACCEPTANCE. Acceptance of this Work Authorization authorizes Contractor to complete the Additional Services as outlined above and is indicated by the signature of the authorized representative of the District and Contractor. Contractor shall commence the aforesaid Additional Services upon the full execution of this Work Authorization and shall perform the same in accordance with the terms and conditions of the Agreement, which, except to the extent expressly altered or changed in this Work Authorization, remains in full force and effect.

IN WITNESS WHEREOF, the parties execute this agreement the day and year first written above.

**SOMERSET COMMUNITY
DEVELOPMENT DISTRICT**

Robert Stenhammer (Jan 22, 2026 13:44:15 CST)

By: Robert Stenhammer

- Chairperson
- Vice Chairperson

JUNIPER LANDSCAPING OF FLORIDA LLC

BRIANCALKINS (Jan 23, 2026 13:38:45 CST)

By: BRIAN CALKINS

Its: Branch Manager

Exhibit A

Proposal for Additional Services

Exhibit A



Proposal

Proposal No.: 379306
Proposed Date: 01/06/26

PROPERTY:	FOR:
Somerset Community Development District Kim O'Mera 84 Elbow Beach Road-Somerset Community Highway 30A Corridor Inlet Beach, FL 32461	Main line repair East Buttery

ITEM	QTY	UOM	UNIT PRICE	EXT. PRICE	TOTAL
Irrigation Renovation					
Lateral Components					\$395.55
Irrigation Tech Labor	2.50	HR	\$75.00	\$187.50	
Misc Irrigation Parts	2.00	EA	\$5.25	\$10.50	
NDS Pro-Span PVC Expansion Repair Coupling 2-1/2 in. Socket x Spigot SLIP FIX	1.00	EA	\$88.95	\$88.95	
2" - 2.5" Misc Fittings	4.00	EA	\$23.50	\$94.00	
PVC Pipe 1 in. x 20 ft. Schedule 40 Bell End (Sold per ft.)	4.00	FT	\$3.65	\$14.60	
				Total:	\$395.55



Guarantee: Any alteration from these specs involving additional costs will be executed only upon written order and will become an extra charge over and above estimate.

Standard Warranty: Juniper Landscaping of Florida LLC agrees to warranty irrigation, drainage and lighting for 1 year, trees and palms for 6 months, shrubs and ground cover for 3 months, and sod for 30 days. This warranty is subject to and specifically limited by the following:

Warranty is not valid on relocated material, annuals and any existing irrigation, drainage and lighting systems. Warranty is not valid on new plant material or sod installed without automatic irrigation. Warranty does not cover damage from pests or disease encountered on site, act of God, or damage caused by others. Failure of water or power source not caused by Juniper Landscaping of Florida LLC will void warranty. The above identified warranty periods commence upon the date of completion of all items included in this proposal. Standard Warranty does not modify or supersede any previously written agreement.

Juniper Landscaping of Florida LLC is not responsible for damage to non-located underground.

Residential Agreement: A deposit or payment in full will be required before any work will begin. Any and all balance will be due upon job completion in full, unless otherwise noted in writing. All work will be performed in a workman like manner in accordance to said proposal. Any additional work added to original proposal will require written approval, may require additional deposits and will be due on completion with any remaining balances owed.

DUE TO THE NATURE OF MATERIAL COST VOLATILITY, WE ARE CURRENTLY HOLDING PRICING FOR THIRTY (30) DAYS FROM PROPOSAL DATE

Signature (Owner/Property Manager)

Date

Printed Name (Owner/Property Manager)

Signature - Representative

Date

**WORK AUTHORIZATION NUMBER 26-03
FOR ADDITIONAL SERVICES**

THIS WORK AUTHORIZATION ("Work Authorization"), dated January 4, 2026, authorizes certain work in accordance with that certain *Landscape and Irrigation Maintenance Services Agreement*, effective January 1, 2026 (the "**Agreement**"), by and between:

SOMERSET COMMUNITY DEVELOPMENT DISTRICT, a local unit of special-purpose government established pursuant to Chapter 190, *Florida Statutes*, located in Walton County, Florida (the "**District**"), and

JUNIPER LANDSCAPING OF FLORIDA LLC, a Florida limited liability company, with an address of 511 N. Highway 79, Panama City Beach, Florida 32413 ("**Contractor**").

SECTION 1. SCOPE OF SERVICES. In addition to the services described in the Agreement and any exhibits, amendments and addenda thereto, Contractor shall provide stone replacement services, as set forth in the attached **Exhibit A**, which is incorporated herein by reference, all in accordance with the terms of the Agreement (collectively, the "**Additional Services**"). To the extent that the terms of **Exhibit A** conflict with terms of this Work Authorization or the Agreement, the Work Authorization and the Agreement shall control.

SECTION 2. COMPENSATION. As compensation for the Additional Services, the District agrees to pay Contractor **Fifty-Seven Thousand Six Hundred Forty-Eight Dollars (\$57,648.00)** due in full upon completion and acceptance of the Additional Services by the District.

SECTION 3. ACCEPTANCE. Acceptance of this Work Authorization authorizes Contractor to complete the Additional Services as outlined above and is indicated by the signature of the authorized representative of the District and Contractor. Contractor shall commence the aforesaid Additional Services upon the full execution of this Work Authorization and shall perform the same in accordance with the terms and conditions of the Agreement, which, except to the extent expressly altered or changed in this Work Authorization, remains in full force and effect.

IN WITNESS WHEREOF, the parties execute this agreement the day and year first written above.

**SOMERSET COMMUNITY
DEVELOPMENT DISTRICT**

Robert Stenhammer (Jan 22, 2026 16:49:39 CST)

By: Robert Stenhammer

- Chairperson
- Vice Chairperson

JUNIPER LANDSCAPING OF FLORIDA LLC

BRIAN CALKINS (Jan 23, 2026 06:27:42 CST)

By: BRIAN CALKINS

Its: Branch Manager

Exhibit A

Juniper

Proposal

Proposal No.: 378863

Proposed Date: 01/04/26

PROPERTY:	FOR:
Somerset Community Development District Kim50'Mera 84 Elbow Beach Road-Somerset Community Highway 30A Corridor Inlet Beach, FL 32461	U 45 Main line

ITEM	QTY	UOM	UNIT PRICE	EXT. PRICE	TOTAL
Irrigation Renovation					
Lateral Components					\$1,082.16
Irrigation Tech Labor	6.00	HR	\$75.00	\$450.00	
Misc Irrigation Parts	2.00	EA	\$13.75	\$27.50	
PVC Pipe 2 1/2 in. x 20 ft. Schedule 40 Bell End (Sold per ft.)	1.00	FT	\$7.96	\$7.96	
NDS Pro-Span PVC Expansion Repair Coupling 2-1/2 in. Socket x Spigot SLIP FIX	1.00	EA	\$86.95	\$86.95	
12 x 17 Deep Meter Valve Box	1.00	EA	\$219.98	\$219.98	
2" Valve	1.00	EA	\$289.77	\$289.77	
Total:					\$1,082.16



Guarantee: Any alteration from these specs involving additional costs will be executed only upon written order and will become an extra charge over and above estimate.

Standard Warranty: Juniper Landscaping of Florida LLC agrees to warranty irrigation, drainage and lighting for 1 year, trees and palms for 6 months, shrubs and ground cover for 3 months, and sod for 30 days. This warranty is subject to and specifically limited by the following:

Warranty is not valid on relocated material, annuals and any existing irrigation, drainage and lighting systems. Warranty is not valid on new plant material or sod installed without automatic irrigation. Warranty does not cover damage from pests or disease encountered on site, act of God, or damaged caused by others. Failure of water or power source not caused by Juniper Landscaping of Florida LLC will void warranty. The above identified warranty periods commence upon the date of completion of all items included in this proposal. Standard Warranty does not modify or supersede any previously written agreement.

Juniper Landscaping of Florida LLC is not responsible for damage to non-located underground.

Residential Agreement: A deposit or payment in full will be required before any work will begin. Any and all balance will be due upon job completion in full, unless otherwise noted in writing. All work will be performed in a workman like manner in accordance to said proposal. Any additional work added to original proposal will require written approval, may require additional deposits and will be due on completion with any remaining balances owed.

DUE TO THE NATURE OF MATERIAL COST VOLATILITY, WE ARE CURRENTLY HOLDING PRICING FOR THIRTY (30) DAYS FROM PROPOSAL DATE

Signature (Owner/Property Manager)

Date

Printed Name (Owner/Property Manager)

Signature - Representative

Date

Tab 4

Tab 5

WORK AUTHORIZATION #26-02

January 29, 2026

Somerset Community Development District
3434 Colwell Avenue, Suite 200
Tampa, Florida 33614

Subject: **Work Authorization Number 26-02 (“Work Authorization”)
Somerset Community Development District**

Dear Board of Supervisors:

Couch Collective, LLC (“Contractor”) is pleased to submit this work authorization to provide paver repair, installation and/or replacement services for the Somerset Community Development District (“District”). We will provide these services pursuant to our current *Agreement for Paver Repair, Installation and Replacement Services* dated April 3, 2025 (“Agreement”) as follows:

I. Scope of Work

The District hereby engages the services of Contractor to perform the work described in **Attachment A**, attached hereto. **Attachment A** shall not be incorporated herein, except that **Attachment A** is applicable to the extent that it states the Work’s scope of services for the labor and materials to be provided under this Agreement and the price. Otherwise, none of the provisions of **Attachment A** shall apply to this Work Authorization and the Agreement.

II. Fees

The District will compensate Contractor at the price listed in **Attachment A** in accordance with the terms of the Agreement and this Work Authorization.

This Work Authorization, together with the Agreement, represents the entire understanding between the District and Contractor with regard to the referenced Work Authorization. If you wish to accept this Work Authorization, please sign below where indicated, and return one complete copy to our office. Upon receipt, we will promptly schedule the approved services.

Sincerely,

Authorized Representative of
Couch Collective, LLC

APPROVED AND ACCEPTED

By: _____
Chair/Vice-Chair, Board of Supervisors
Somerset Community Development District

Date: _____

Attachment A

ESTIMATE

Couch Collective LLC
30 Evelyn Ave
Santa Rosa Beach, FL 32459-0607

mason@collectivellc
+1 (678) 736-9304



Bill to
Alys Beach - CDD

Estimate details
Estimate no.: 1076
Estimate date: 01/29/2026

#	Product or service	Description	Qty	Rate	Amount
1.	CDD - Alys Road Paver (1/26' List)	CDD 1. Entrance to Town Op's - 80 SF 2. Nonesuch and E La Garza - stained - 75SF 3. S Salthouse Ln entrance - 55 SF * Includes Curb Repair * See Collective Markup of AB Master Plan for Locations of Repairs	1	\$5,880.00	\$5,880.00
				Total	\$5,880.00

Accepted date

Accepted by

ESTIMATE

Couch Collective LLC

30 Devlieg Ave

Santa Rosa Beach, FL 32459-0607

mason@ccollective.llc

+1 (678) 736-9304



Bill to

Alys Beach - CDD

Estimate details

Estimate no.: 1076

Estimate date: 01/29/2026

#	Product or service	Description	Qty	Rate	Amount
1.	CDD - Alys Road Paver (1/26' List)	CDD 1. Entrance to Town Op's - 80 SF 2. Nonesuch and E La Garza – stained - 75SF 3. S Salthouse Ln entrance - 55 SF * Includes Curb Repair * See Collective Markup of AB Master Plan for Locations of Repairs	1	\$5,880.00	\$5,880.00
				Total	\$5,880.00

Accepted date

Accepted by



CDD
 1. Entrance to Town Op's
 2. Nonesuch and E La Garza – stained
 3. S Salthouse Ln entrance
 * Includes Curb Repair

~ 300 SF Total

ABNA
 1. Entrance to employee parking
 2. Nonesuch @ Zuma
 3. Nonesuch and N Castle Harbour – manhole
 4. Entrance to Georges off N Castle Harbour
 *Will Address Grade Issue at Curb
 5. Admiralty Row @ the NE corner of the Ampitheater – sunk
 6. N Charles @ Papillio Park
 * Same SOW as McGee Rework
 7. Whitten Way @ Silva – sunk again
 8. Longtail @ Silve – manhole
 9. S Castle Harbour and Sea Garden
 10. Georges Parking Lot

- 925 SF Total (Does not Include #6, see Estimate for Clarification)

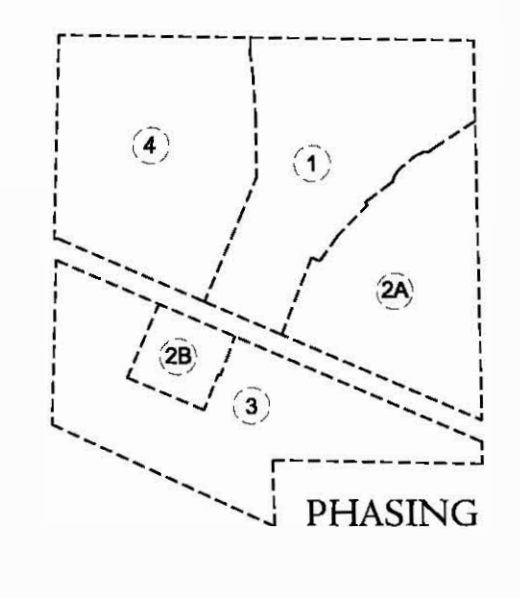
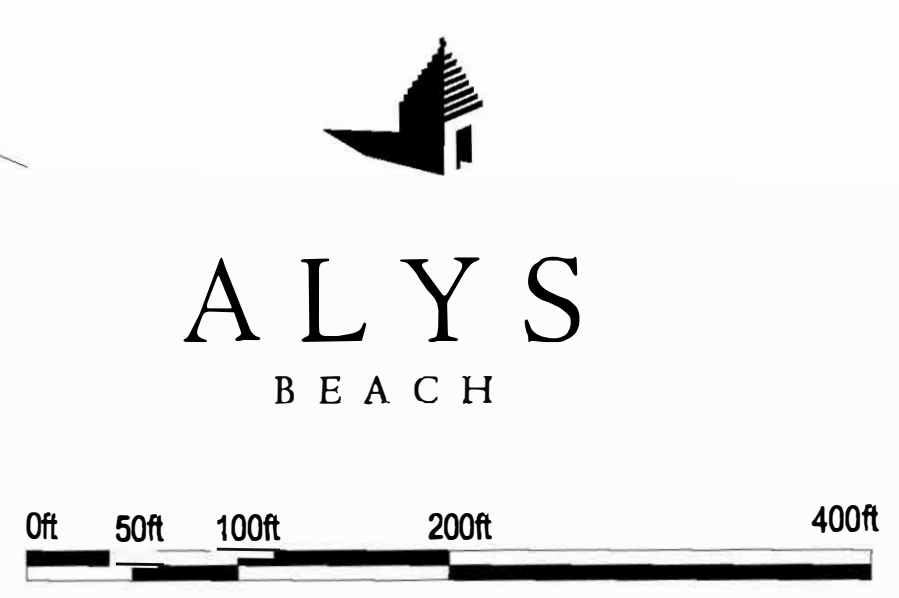

OVERALL MASTER PLAN
 March 2025
 REFERENCE ONLY

Tab 6



UPCOMING DATES TO REMEMBER

- Next Meeting: February 5, 2026
- FY 2023-2024 Audit Completion Deadline: June 30, 2026
- Next Election (Seats 1, 4, & 5): November 2026

District
Manager's
Report

February 5

2026

S
O
M
E
R
S
E
T

C
D
D

<u>FINANCIAL SUMMARY</u>		December 31, 2025	
General Fund Cash & Investment Balance:		\$	850,032.00
Reserve Fund Cash & Investment Balance:		\$	3,118,858.00
Total Cash and Investment Balances:		\$	3,968,890.00
Liabilities (AP & Accrued Expenses):		\$	(50,380.00)
		\$	3,918,510.00
General Fund		Reserve Fund	
FY25/26 Budget	\$ 958,252.00	FY25/26 Budget	\$ 707,000.00
TYD Expenditures	\$ (319,783.00)	TYD Expenditures	\$ 44,755.00
YTD Budget - 4/30/25	\$ 270,221.00	Remaining FY Budget	\$ 751,755.00
YTD Budget Trend (over)/under:	\$ (49,562.00)		
Remaining FY26 Budget	\$ 638,469.00		



Noteworthy Items

1. FY26 Reserve Study Update: Ready to begin upon receipt of Stormwater report.
2. Budget Schedule
 - Proposed Budget: April 2, 2026
 - Final Budget: August 6, 2026
3. Action Item List:

**Somerset Community Development District
FY25/26 Action Items
January 29, 2025**

Meeting Date/ Date Added	Meeting Item	Item	Status	Owner	Description	Notes
12/04/25	YES	30A Rock Replacement	In Progress	District Manager/ Landscape Vendor	Approved, \$57,648.00, using a Work Authorization form tied to the new agreement. Reserves	Executed 1/02/26
08/07/25	YES	Dune Summary	In Progress	District Counsel / District Manager	Informational summary for beachfront lot owners.	
08/07/25	YES	Stormwater Assessment, Conditions, Restoration	In Progress	District Engineer	Approved, \$180K, Reserves	
08/07/25	YES	Water Use Analysis	In Progress	District Engineer	DE to review water usage data and consult BOS	
02/20/25	NO	Update Memorandum of Understanding (MOU)	In Progress	District Manager/ Town Operations/ CDD Chair/ HOA President	Enhance current MOU to clarify areas of need and discuss any additional areas needed.	2/20/25: Submitted comments with request for input to TO, Chair, and President.
09/05/24	YES	Updated Reserve Study	In Progress	District Manager District Counsel	Obtain a proposal from Association Reserves for a new Reserve Study, present at the next meeting.	Additional work needed to capture funding needs, to incorporate information presented in stormwater reports.
12/04/25	YES	FY25/26 Goals & Objectives	Closed	District Manager		
12/04/25	YES	Landscape Maintenance Greement	Closed	District Counsel / District Manager	Approved, \$111,640.00 annually	Executed
08/07/25	YES	Update to Pavement Management Manual	Closed	District Engineer	Approved, \$4,800	